

## **RAM 78100 Series Hydraulic Release Bearing Instructions**



**WARNING:** This bearing is designed for use with Ram 6.25, 7.25, Coupler, and other multiple disc racing clutches. This bearing has a total travel of .500" and will not work with stock type clutches requiring more travel than .500".

This hydraulic bearing is designed to work with a .750" master cylinder.

**Use only a DOT 3 or equivalent non-silicone brake fluid. Use of other petroleum based fluids will result in o-ring failure.**

Before installing you bearing check the bellhousing for proper alignment to the engine block. Misalignment between the bellhousing and engine block will lead to problems with the release bearing and premature failure of the clutch assembly. Check your bellhousing manufacturer's instructions for alignment instructions.

To check alignment use a dial indicator with the base mounted to the crank flange to check the transmission pilot hole for concentricity to the crankshaft centerline within  $\pm .010$ ". Check the face of the bellhousing (where the transmission mounts) for squareness to the back of the block. Variance should be no more than  $\pm .010$ " side to side and top to bottom.

### **Installing the Hydraulic Bearing**

Remove two of the transmission retainer bolts opposite each other. Replace them with the enclosed studs (5/16" or 3/8"). Install a jam nut on each stud and tighten against the retainer. Now replace the remaining two retainer bolts with studs and tighten with the jam nut.

Install two more jam nuts on each of the four studs loosely against the first jam nut.

Secure the 1/8" pipe to #4 and bleed fittings in the bearing assembly. The 1/8" pipe fitting should be located on the bottom of the housing when positioned over the bearing retainer.

Slide the hydraulic release bearing over the bearing retainer with the inlet and bleed fittings towards the fork opening in the bellhousing.

With the bellhousing and clutch installed measure the distance from the bellhousing face to the clutch fingers.

Then measure the distance from the release bearing face to the transmission mounting surface. Adjust the jam nuts out equally on the bearing retainer studs until the distance from the bearing face to the transmission mounting surface is .125" less than the distance from the bellhousing face to the clutch fingers (dimension 'A')

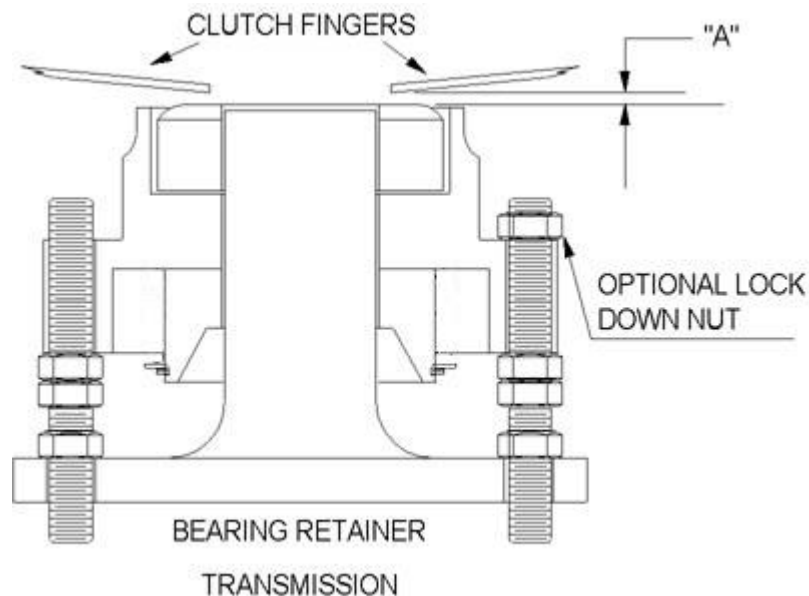

After making sure this is correct and the jam nuts are positioned equally from the transmission mounting surface use the middle jam nut to secure the position of the top jam nut.

Attach a #4 line to the inlet fitting and then install the transmission. There should be .125" clearance between the release bearing and clutch fingers. If there is not remove the transmission and repeat the previous step.

Now bleed the system thoroughly.

Part Number 78100 & 78200 includes:

1 – 78100 bearing assembly

1 – 1/8" pipe to #4 fitting

1 - bleed fitting

4 – 5/16" x 2 1/2" studs

4 – 3/8" x 2 1/2" studs

12 – 5/16" jam nuts

12 – 3/8" jam nuts